



# REGENT EDUCATION & RESEARCH FOUNDATION GROUP OF INSTITUTIONS

Ref: RERF/R&D/Grant/2021-22/Dec/01

Date:10/12/2021

## SANCTION LETTER

To,  
The HoD (All Dept.)  
RERF,  
Barrackpore.

### Sub: Disbursement of Grant for the Patent filed.

Sir/Madam,

It is for the information of all the Head of the Department that on approval of R&D Cell a sum of **Rs. 10000/-** has been sanctioned by the College Authority as the assistance for publication patent.

Sl. No	Name of The Project	Department	Amount Sanctioned
1	HYBRID CROW-SEARCH ALGORITHM WITH PARTICLE SWARM OPTIMIZATION IN LOAD FREQUENCY CONTROL (LFC).	EE	10000

Principal  
RERF



Campus : Regent Education & Research Foundation Group of Institutions

E-mail : [rerfkolkata@gmail.com](mailto:rerfkolkata@gmail.com), Website : [www.rerf.in](http://www.rerf.in)

*Campus Address:*

Bara Kanthalia, Barrackpore  
P.O: Sewli Telinipara, P.S.: Titagarh  
Kolkata - 700 121  
Tel.: 033-3008-5442/432/431, Fax: 033-3008-5442

*Regd. Office Address:*

11/3, Biresb Guha Street  
7<sup>th</sup> Floor, Kolkata - 700 017  
Tel.: 033-3221-3013



# REGENT EDUCATION & RESEARCH FOUNDATION GROUP OF INSTITUTIONS

Ref: RERF/R&D/Grant/2021-22/Mar/02

Date:11/03/2022

## SANCTION LETTER

To,  
The HoD (All Dept.)  
RERF,  
Barrackpore.

### Sub: Disbursement of Grant for R&D Projects approved

Sir/Madam,

It is for the information of all the Head of the Department that on approval of R&D Cell a sum of **Rs. 13200/-** has been sanctioned by the College Authority for the fabrication/ preparation of technical projects approved.

The detailed list mentioning the amount allotted for each department is given below:

Sl. No	Name of The Project	Department	Amount Sanctioned
1	TRAFFIC BLINKER LIGHT BY SOLAR SYSTEM	EEE	7900
2	AUTOMATIC SOLAR STREET LIGHT	EE	5300

Principal  
RERF



Campus : Regent Education & Research Foundation Group of Institutions

E-mail : [rerfkolkata@gmail.com](mailto:rerfkolkata@gmail.com), Website : [www.rerf.in](http://www.rerf.in)

*Campus Address:*

**Bara Kanthalia, Barrackpore**  
P.O: Sewli Telinipara, P.S.: Titagarh  
Kolkata - 700 121  
Tel.: 033-3008-5442/432/431, Fax: 033-3008-5442

*Regd. Office Address:*

**11/3, Biresw Guha Street**  
7<sup>th</sup> Floor, Kolkata - 700 017  
Tel.: 033-3221-3013



# Regent Education & Research Foundation Group of Institutions

## R&D PROJECT PROPOSAL

(To be filled by the applicant)

1. Title of the project: **TRAFFIC BLINKER LIGHT by SOLAR SYSTEM**
2. Name of the Applicant: DR. SUMAN KUMAR DEY
3. Name, Designation, Affiliation of Principal Investigator:  
  
DR. SUMAN KUMAR DEY  
Associate Professor, REGENT EDUCATION & RESEARCH FOUNDATION
4. Name, Designation, Affiliation of Co-PI (if any): NA
5. Collaborating Institute (if any): NA
6. Broad Subject area of the Project Proposal (Ex. Electrical Engineering):  
  
Electrical Engineering
7. Abstract (Maximum 150 words): Traffic Blinker Light is an autonomous LED Flashing system Its purpose is to warn motorist and emphasis them to speed control when reach close to school, fire station, military zone, village road, small town, pedestrian cross walk, diversions, blind or sharp turns where the motorist are unable to judge the route or direction and severe hazard ahead. It blinks (flash) at specified rate (can be customised). The solar panel receives the sunlight to generate electricity, and the controller of which is used for battery charging. The controller has functions of preventing inverted connection, inverted charging, excessive discharge, overcharging and overloading and automatic protection for short circuit, boasting features such as automatic identification of day and night, automatic detection of voltage, automatic storage battery protection, easy installation and no pollution. The battery discharges electricity to the signal machine, transmitter, receiver and signal light via the controller.
8. Total Duration (Months): 3 months
9. Plan of Work: (500 characters):

1<sup>st</sup> Month: Fabrication of solar panel and control unit.

2<sup>nd</sup> Month: Connection of solar panels and battery storage unit to the signal machine, transmitter, receiver and signal light.

3<sup>rd</sup> Month: Trial of system and completion of project.

10. Do you need any Instruments/ facilities outside the Institute(List out within 500 characters):

Sl. No.	Name	Description
1.	SOLAR PANEL	Components required for fabrication of model
2.	CHARGE CONTROLLER	Components required for fabrication of model
3.	BATTERY	Components required for fabrication of model
4.	RELAY	Components required for fabrication of model
5.	SIGNAL LIGHT	Components required for fabrication of model
6.	POLE	Components required for fabrication of model
7.	BATTERY MOUNTING BOX	Components required for fabrication of model

11. Total estimated cost (In Rupees and in Words): **Rs. 7900/-** (Rupees seven thousand nine hundred only).

12. Summary of the budget

Items	BUDGET (In Rupees)			
	1st Month	2nd Month	3rd Month	Total
Year				
A. Recurring:	b. 1600	0	0	1600
a. Remunerations				
b. Consumables				
c. Travel				
d. Othercosts				
B. Non-recurring Permanent equipment/ publication/software*	0	6300	0	6300
<b>Grand Total (A+B)</b>	1600	6300	0	<b>7900</b>

Date..... 22/2/22 .....

Place..... RERF .....

Issued for payment..... **7900/-** .....

(In Words)..... Seven thousand nine hundred only .....

Sayan Exha  
(Name and signature of the Applicant)

*[Signature]*  
Principal  
RERFGI, Barrackpore  
(Name and signature of Head of the Department)



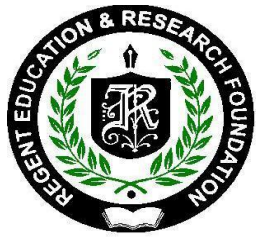

### TRAFFIC BLINKER LIGHT by SOLAR SYSTEM

#### Introduction

Traffic Blinker Light is an autonomous LED Flashing system Its purpose is to warn motorist and emphasis them to speed control when reach close to school, fire station, military zone, village road, small town, pedestrian cross walk, diversions, blind or sharp turns where the motorist are unable to judge the route or direction and severe hazard ahead. It blinks (flash) at specified rate (can be customised).



However, these signals come with some rules associated with them. Basically, the traffic signal rules form the very backbone of these signs and following them is vital for ensuring smooth and risk-free road travel. A traffic signal is used as an instructing device that indicates the road user to act according to the displayed sign. Following the traffic signal ensures road safety and to make things simple to understand, these signals have been using a universal colour code.

In recent years, with the rapid growth of privacy car, urban road transportation load enlarges suddenly and many roads' sections approach to saturated limit in peak time interval. Traffic congestion has been the universal problem for most big cities. Traffic congestion is one of the worldwide urban problems, which can lengthen journey time, increase energy consumption, aggravate environmental pollution and result in traffic accident. If we take no measure to govern it, not only individual journey cost will be enhanced, but also the entire municipal transportation system will paralysis and urban sustainable development will be restricted. Therefore, how to solve traffic congestion becomes the hot issue for each big city.

The essence of traffic congestion is the unbalance transportation of supply and demand. Increasing road supply is one kind of solutions to alleviate supply and demand contradictory. However, practices coming from various countries indicated that dependence on constructing more roads would inevitably result in the vicious circle of "traffic congestion -road building -congestion alleviation - attracting more transportation demand - producing new congestion - building more roads", which could not truly solve the traffic congestion problem. Therefore, more and more experts hope to find new breach from the demand management aspect and have proposed many demand management methods, in which traffic congestion charging as one of the effective measures has aroused widespread interest in city administration department.

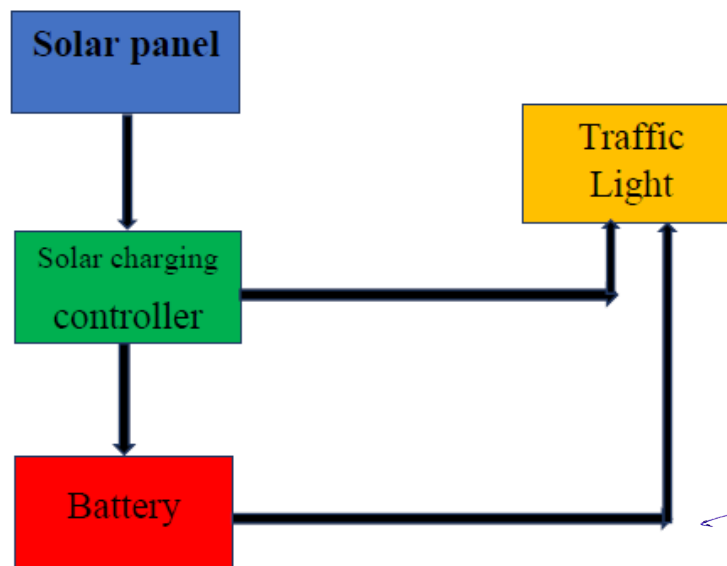
#### Proposed System design & Operation:



Campus : Regent Education & Research Foundation Group of Institutions

E-mail : [rerfkolkata@gmail.com](mailto:rerfkolkata@gmail.com), Website : [www.rerf.in](http://www.rerf.in)

#### Campus Address:

**Bara Kanthalia, Barrackpore**  
**P.O: Sewli Telinipara, P.S.: Titagarh**  
**Kolkata - 700 121**  
**Tel.: 033-3008-5442/432/431, Fax: 033-3008-5442**

#### Regd. Office Address:

**11/3, Biresw Guha Street**  
**7<sup>th</sup> Floor, Kolkata - 700 017**  
**Tel.: 033-3221-3013**



# REGENT EDUCATION & RESEARCH FOUNDATION

## Group of Institutions

The solar panel receives the sunlight to generate electricity, and the controller of which is used for battery charging. The controller has functions of preventing inverted connection, inverted charging, excessive discharge, overcharging and overloading and automatic protection for short circuit, boasting features such as automatic identification of day and night, automatic detection of voltage, automatic storage battery protection, easy installation and no pollution. The battery discharges electricity to the signal machine, transmitter, receiver and signal light via the controller.

### Cost:

SL.NO	APPARATUS NAMES	APPARATUS QUANTITIES	APPARATUS PRICES (in Rs.)
01	SOLAR PANEL	1	600
02	CHARGE CONTROLLER	1	800
03	BATTERY	1	1500
04	RELAY	1	200
05	SIGNAL LIGHT	1	2000
06	POLE	1	2300
07	BATTERY MOUNTING BOX	1	500
TOTAL PRICES (in Rs.)			7900



### Conclusion

By this project, we are trying to establish an approach through which we are providing hands on training of our students to the renewable energy as well as make our campus green. In old scenario by making the poster or painting we have to intimate that school or college ahead. By implementing this project, we are conveying the same message digitally i.e., through signal.

### Reference

[1] ELECTRONIC TRAFFIC SIGNAGE & EL SEGUNDO, CA US, "An illuminated display apparatus for supplementing street signals includes a housing containing an LED array capable of producing multicoloured and animated images, a bracket system holding the housings together wherein a row of multiple housings and LED arrays may be assembled together to create larger displays, and wherein a system of brackets supports the housings at an angle from vertical for viewing by passing vehicles below. The display may also include a solar array, loudspeakers, strobe apparatus and automatic brightness dimming."

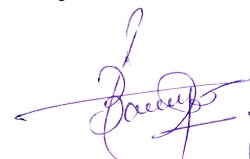
[2] Emergency traffic light system & EL SEGUNDO, CA US, "A supplemental system of stop lights for use in conjunction with a primary stop light system. Solar powered supplemental stop light units are mechanically attached nearby the stop light units of the primary system. Should the primary system fail, the supplemental stop lights become active to re-establish control of the traffic flow and substitute for the disabled primary stop light system. The supplemental stop light system uses at least two visual displays: a graphics display and an alphanumeric verbal display. In an alternative use in conjunction with emergency vehicle traffic, an alphanumeric numeric display can be advantageously."

Campus : Regent Education & Research Foundation Group of Institutions

E-mail : [rerfkolkata@gmail.com](mailto:rerfkolkata@gmail.com), Website : [www.rerf.in](http://www.rerf.in)

#### Campus Address:

**Bara Kanthalia, Barrackpore**  
**P.O: Sewli Telinipara, P.S.: Titagarh**  
**Kolkata - 700 121**  
**Tel.: 033-3008-5442/432/431, Fax: 033-3008-5442**

#### Regd. Office Address:

**11/3, Biresh Guha Street**  
**7<sup>th</sup> Floor, Kolkata - 700 017**  
**Tel.: 033-3221-3013**

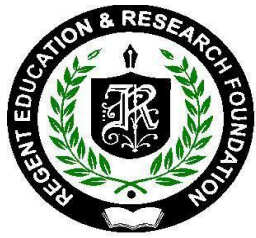



# REGENT EDUCATION & RESEARCH FOUNDATION

## Group of Institutions

### Geo-Tagged Image:



Campus : Regent Education & Research Foundation Group of Institutions

E-mail : [rerfkolkata@gmail.com](mailto:rerfkolkata@gmail.com), Website : [www.rerf.in](http://www.rerf.in)

**Campus Address:**

**Bara Kanthalia, Barrackpore**  
**P.O: Sewli Telinipara, P.S.: Titagarh**  
**Kolkata - 700 121**  
**Tel.: 033-3008-5442/432/431, Fax: 033-3008-5442**

**Regd. Office Address:**

**11/3, Biresh Guha Street**  
**7<sup>th</sup> Floor, Kolkata - 700 017**  
**Tel.: 033-3221-3013**



# Regent Education & Research Foundation Group of Institutions

## R&D PROJECT PROPOSAL

(To be filled by the applicant)

1. Title of the project: **AUTOMATIC SOLAR STREET LIGHT**
2. Name of the Applicant: BIDYUT KUMAR GHOSH
3. Name, Designation, Affiliation of Principal Investigator: BIDYUT KUMAR GHOSH  
Assistant Professor, REGENT EDUCATION & RESEARCH FOUNDATION
4. Name, Designation, Affiliation of Co-PI (if any): NA
5. Collaborating Institute (if any): NA
6. Broad Subject area of the Project Proposal (Ex. Electrical Engineering):  
Electrical Engineering
7. Abstract (Maximum 150 words): Many conventional street lights are energy efficient, but some extremely old street lights that are still in use are not. If the systems are configured properly, solar photovoltaic street lighting have the potential to be very energy-efficient. Contrary to typical street lighting, solar street lighting is a relatively new invention. There is no electrical power grid connection for these street lights; instead, the solar light will generate its own energy from the sun (photovoltaic panel) and store it in a battery until it is sufficiently dark for the light to turn on. Off-grid solar illumination applications come in a variety of forms. A micro grid, which is effectively a miniature power grid used only for the lights, is one way the solar panels can be connected. Solar photovoltaic technology uses an electronic process that takes place in specific materials known as semiconductors to produce power directly from sunshine.
8. Total Duration (Months): 3 months
9. Plan of Work: (500 characters):  
1<sup>st</sup> Month: Fabrication of solar panel and control unit.  
2<sup>nd</sup> Month: Connection of solar panels in micro grid and testing of battery storage unit.  
3<sup>rd</sup> Month: Trial of system and completion of project.
10. Do you need any Instruments/ facilities outside the Institute(List out within 500 characters):

Sl. No.	Name	Description
1.	JUNCTION BOX	Components required for fabrication of model
2.	VERO BOARD	Components required for fabrication of model



3.	CONNECTER	Components required for fabrication of model
4.	555-IC	Components required for fabrication of model
5.	TRANSISTER	Components required for fabrication of model
6.	VR POT	Components required for fabrication of model
7.	INDICATOR LEDS	Components required for fabrication of model
8.	RELAY	Components required for fabrication of model
9.	WIRES	Components required for fabrication of model
10.	DC LED (25W)	Components required for fabrication of model
11.	SMPS	Components required for fabrication of model
12.	NUTSPSCURES	Components required for fabrication of model
13.	BATTERY 12V 42AH	Components required for fabrication of model

11. Total estimated cost (In Rupees and in Words): **Rs. 5301/-** (Rupees five thousand three hundred and one only).

12. Summary of the budget

Items	BUDGET (InRupees)			
	1 <sup>st</sup> Month	2 <sup>nd</sup> Month	3 <sup>rd</sup> Month	Total
Year				
A. Recurring:				
a. Remunerations				
b. Consumables	b. 1201	0	d. 100	1301
c. Travel				
d. Othercosts				
B. Non-recurring Permanent equipment/ publication/software*	0	4000	0	4000
<b>Grand Total (A+B)</b>	1201	4000	100	<b>5301</b>

Date.....24/2/22.....

Place.....R.F.R.F.....

Akash Das

EE - 3<sup>rd</sup> YR (B.Tech)  
(Name and signature of the  
Applicant)

Bidyut Kumar Ghosh

(Name and signature of the  
Head of the Department)

Passed for payment... **5301/-** .....  
(In Words)..... Five thousand three  
hundred one only.....

[Signature]  
Principal  
RERFGI, Barrackpore

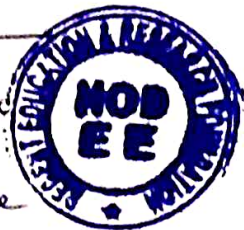



# REGENT EDUCATION & RESEARCH FOUNDATION

## Group of Institutions

### AUTOMATIC SOLAR STREET LIGHT

#### Introduction

Since people have been coexisting, there has been street lights. Ancient Romans used oil lamps filled with vegetable oil in front of their homes as early as 500 BC. William Murdock utilized a coal gas-powered gas light in 1802. Soon after, in 1807, the English city of London made the decision to employ gas lights to illuminate a full street rather than simply the fronts of homes. These gas lamps were first used in the United States in 1816, though. The first city to use gas lights was Baltimore, Maryland. Improvements were made to the gas lights, and the more energy-efficient electric lights were switched in their place.

The first electric street light to use arc lamps was the Yablochkov Candle, created by Pavel Yablochkov in 1875. In Paris, France, three years later, the city started replacing the gas lamps with electric ones and had already replaced roughly 4,000 street lights. In response, 130,000 arc lighting were placed on numerous city streets in the United States by 1890. Once electric street lights were introduced, advancements were made gradually. There are many different lights available today. Many conventional street lights are energy efficient, but some extremely old street lights that are still in use are not. If the systems are configured properly, solar photovoltaic street lighting have the potential to be very energy-efficient. The differences between conventional and solar illumination will be discussed.

Contrary to typical street lighting, solar street lighting is a relatively new invention. There is no electrical power grid connection for these street lights; instead, the solar light will generate its own energy from the sun (photovoltaic panel) and store it in a battery until it is sufficiently dark for the light to turn on. Off-grid solar illumination applications come in a variety of forms. A micro grid, which is effectively a miniature power grid used only for the lights, is one way the solar panels can be connected. Another option is for each street light to operate independently.

Solar photovoltaic technology uses an electronic process that takes place in specific materials known as semiconductors to produce power directly from sunshine. Nowadays, thin-film semiconductors or crystalline silicon are used to make the majority of solar cells. Although expensive, silicon has been found to be quite effective at turning sunlight into power. Thin-film materials are occasionally utilized because they are more affordable. The drawback is that these materials need greater surface area to generate electricity and are less efficient than silicon.

#### Proposed system for Trial:

Our proposed system is sub divided into four sections:

1. Solar Panel
2. Control Unit
3. Battery storage unit
4. DC Light.

During the day time solar panel receives its I/P from the Sun rays. At the same time the control unit is also functioning for charging the battery and giving the over voltage protection also. At sunset Solar panel is unable to receive the I/P from the sun and the light will be functioned through control unit.

When the battery storage unit is reaches to 90% discharge condition, the storage unit will be automatically disconnected and light will remain ON condition through the main power supply. This action is also being performed by the control unit.

Again, during the time of Sunrise, the light will be going to OFF condition through control unit and the battery will get charged and the cycle is going on.

Campus : Regent Education & Research Foundation Group of Institutions

E-mail : [rerfolkata@gmail.com](mailto:rerfolkata@gmail.com), Website : [www.rerf.in](http://www.rerf.in)

#### Campus Address:

**Bara Kanthalia, Barrackpore**  
**P.O: Sewli Telinipara, P.S.: Titagarh**  
**Kolkata - 700 121**  
**Tel.: 033-3008-5442/432/431, Fax: 033-3008-5442**

#### Regd. Office Address:

**11/3, Biresuh Guha Street**  
**7<sup>th</sup> Floor, Kolkata - 700 017**  
**Tel.: 033-3221-3013**



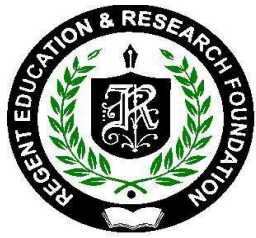

# REGENT EDUCATION & RESEARCH FOUNDATION

## Group of Institutions

### Block Diagram:

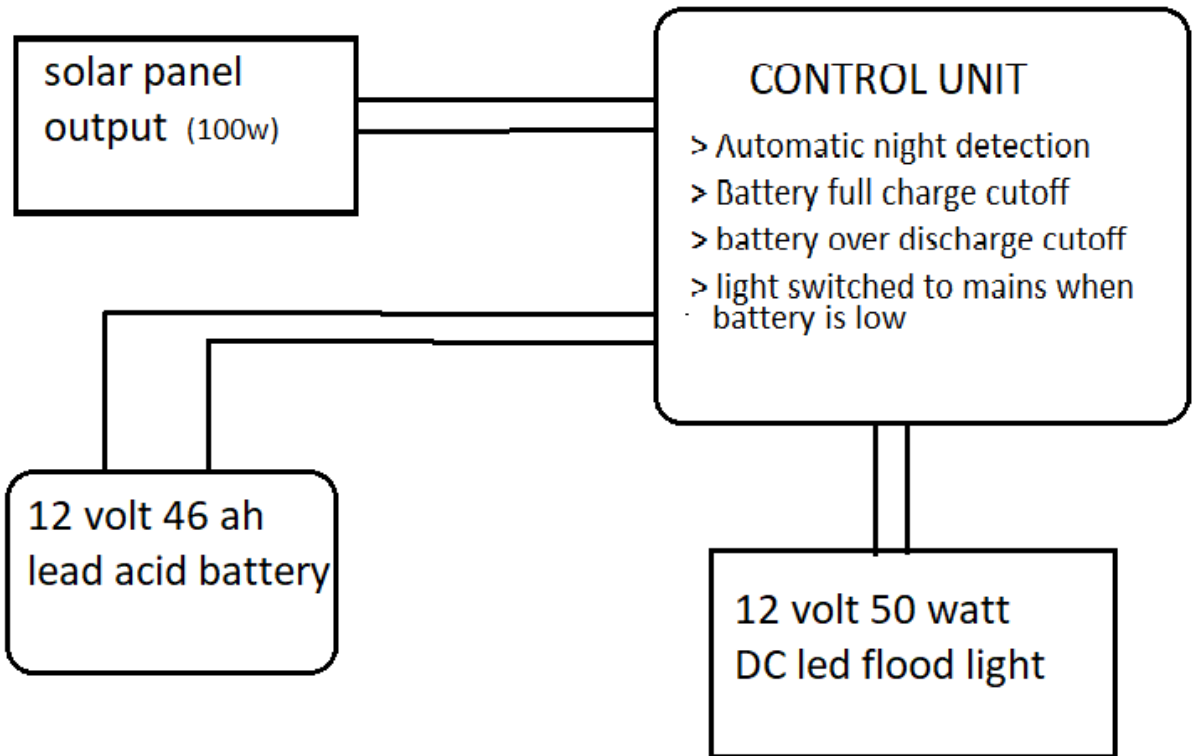

### Cost:

SL.NO	APPARATUS NAMES	APPARATUS QUANTITYS	APPARATUS PRICES (in Rs.)
01	JUNCTION BOX	1	55
02	VERO BOARD	1	55
03	CONNECTER	4	52
04	555-IC	1	24
05	TRANSISTER	4	20
06	VR POT	4	25
07	INDICATOR LEDS	5	20
08	RELAY	2	50
09	WIRES		50
10	DC LED (25W)	2	300
11	MAKING COST		100
12	SMPS	1	500
13	NUTSPSCURES		50
14	BATTERY	12V 42AH	4000
TOTAL PRICES (in Rs.)			<b>5301</b>

### Conclusion

By this project, we are trying to establish an approach through which we are provided hands on training of our students to the renewable energy as well as make our campus green. Definitely the initial cost of this

Campus : Regent Education & Research Foundation Group of Institutions

E-mail : [rerfkolkata@gmail.com](mailto:rerfkolkata@gmail.com), Website : [www.rerf.in](http://www.rerf.in)

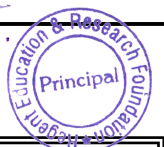

#### Campus Address:

**Bara Kanthalia, Barrackpore**  
**P.O: Sewli Telinipara, P.S.: Titagarh**  
**Kolkata - 700 121**  
**Tel.: 033-3008-5442/432/431, Fax: 033-3008-5442**

#### Regd. Office Address:

**11/3, Biresw Guha Street**  
**7<sup>th</sup> Floor, Kolkata - 700 017**  
**Tel.: 033-3221-3013**

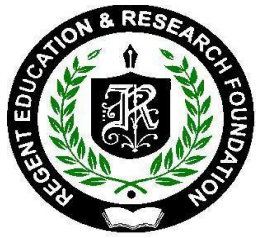

# REGENT EDUCATION & RESEARCH FOUNDATION

## Group of Institutions

type flood lighting system is higher in comparison with traditional flood lighting system. But cost associated with energy consumption will be affected to some extent.

Last but not the least it should be mentioned that this system is implemented in trial basis but in future we will trying to cover all the flood lighting of our campus under this category.

### Reference

- <https://inhabitat.com/sandia-solar-glitter-can-fit-into-and-power-devices-of-any-size-or-shape/>
- [http://www.lrc.rpi.edu/programs/NLPIP/PDF/VIEW/SR\\_StreetlightsLocal.pdf](http://www.lrc.rpi.edu/programs/NLPIP/PDF/VIEW/SR_StreetlightsLocal.pdf)
- <http://blog.lightinus.com/comparing-traditional-street-lights-and-solar-energy-lights>
- <https://www.engoplanet.com/single-post/COMPARING-COST-TRADITIONAL-STREET-LIGHTS-VSSOLAR-POLES>
- <http://www.geni.org/globalenergy/research/renewable-energy-on-tribal-lands/RenewableEnergy-on-Tribal-Lands.pdf>
- <http://www.renewableenergyworld.com/geothermal-energy/tech/geoelectricity.html>
- <http://www.homeadvisor.com/cost/heating-and-cooling/install-a-geothermal-heating-or-cooling-system/>
- <https://www.engoplanet.com/single-post/Cost-Comparison-Solar-LED-lights-traditional>
- <https://www.firstenergycorp.com/content/dam/customer/get-help/files/savingenergy/pastreetlights/ledfactsheet-cobrahead-pn.pdf>

### Geo-Tagged Image:



Campus : Regent Education & Research Foundation Group of Institutions

E-mail : [rerfkolkata@gmail.com](mailto:rerfkolkata@gmail.com), Website : [www.rerf.in](http://www.rerf.in)

#### Campus Address:

**Bara Kanthalia, Barrackpore**  
**P.O: Sewli Telinipara, P.S.: Titagarh**  
**Kolkata - 700 121**  
**Tel.: 033-3008-5442/432/431, Fax: 033-3008-5442**

#### Regd. Office Address:

**11/3, Biresh Guha Street**  
**7<sup>th</sup> Floor, Kolkata - 700 017**  
**Tel.: 033-3221-3013**



# Regent Education & Research Foundation Group of Institutions

## R&D PROJECT PROPOSAL

(To be filled by the applicant)

1. **Title of the project:** Hybrid crow-search algorithm with particle swarm optimization in load frequency control (LFC).
2. **Name of the Applicant:** Dr. Arindita Saha
3. **Name, Designation, Affiliation of Principal Investigator:** Dr. Lalit Chandra Saikia,  
Associate Professor, NIT Silchar
4. **Name, Designation, Affiliation of Co-PI (if any):** Dr. Arindita Saha
5. **Collaborating Institute (if any):** NA
6. **Broad Subject area of the Project Proposal:** The present invention generally relates to the field of hybridization techniques. More particular, the present invention relates to a field of managing power mismatch by achieving synchronization using hybridization techniques
7. **Abstract (Maximum 150 words):** A method for hybrid crow-search algorithm with particle swarm optimization (hCA-PSO), comprises of: setting values of flock size, iteration, random number, flight length, awareness probability and memory for the hCA-PSO; assigning a position and memory to crow of the hybrid crow-search algorithm; evaluating fitness using a transfer function of a tilt-integral-derivative with filter (TIDN) controller, wherein if random number is greater than awareness probability, then a new crow position is generated using the crow search algorithm, else a current position is retained; updating assigned memory with the new crow position if current retained position is greater than memory, else the current position is retained in the memory; and obtaining best position of crow with optimum controller parameters if number of interactions is less than maximum value of iterations providing as the setting values.
8. **Total Duration (Months):** 6
9. **Plan of Work (Max 500 Words):**  
1<sup>st</sup> Year: Hybridization of crow search algorithm with particle swarm optimization in load frequency control→optimize the values of PID, PIDN and the proposed cascade TIDN controller→incorporate AC-HVDC tie line by replacing AC tie lines and to analyse its dynamic responses using finest controller.  
2<sup>nd</sup> Year: NA

10. Do you need any Instruments/ facilities outside the Institute (Max 500 Words): NA

Sl. No.	Name	Description
1.	NA	NA

11. Total estimated cost (In Rupees and in Words): ₹ 30,000 (Rupees thirty thousand only)

12. Summary of the budget

Items	BUDGET (In Rupees)			
	1 <sup>st</sup> Year	2 <sup>nd</sup> Year	3 <sup>rd</sup> Year	Total
A. Recurring: a. Remunerations b. Consumables c. Travel d. Other costs	NA	NA	NA	NA
B. Non-recurring Permanent equipment/ publication/ software *	₹ 30,000	NA	NA	NA
<b>Grand Total (A+B)</b>	<b>₹ 30,000</b>	NA	NA	NA

Date: 15/11/21  
Place: RERF

Received  
By  
For  
Date

Arindita Saha

Dr. Arindita Saha  
Asst. Prof. EE Dept.  
(Name and signature of the  
Applicant)

Bidyut Kumar Ghosh

Bidyut Kumar Ghosh  
HOD EE Dept.  
(Name and signature of the  
Head of the Department)



Passed for payment... 30,000/-  
(In Words)... Thirty thousand only

Principal  
RERF, Barrackpore



Australian Government

IP Australia

# Register of Patents

Patents Act 1990

## Innovation Patent

Patent no: 2021105834

**Patentee(s):** Bhagat, Sanjeev Kumar of Department of Electrical Engineering  
National Institute of Technology Silchar Assam 788010 India  
Saha, Arindita of Department of Electrical Engineering Regent  
Education and Research Foundation Group of Institutions Kolkata  
WB 700121 India  
Babu, Naladi Ram of Department of Electrical Engineering National  
Institute of Technology Silchar Assam 788010 India  
Saikia, Lalit Chandra of Department of Electrical Engineering  
National Institute of Technology Silchar Assam 788010 India

**Inventor(s):** Babu, Naladi Ram  
Saikia, Lalit Chandra  
Bhagat, Sanjeev Kumar  
Saha, Arindita

**Title:** HYBRID CROW-SEARCH ALGORITHM WITH PARTICLE  
SWARM OPTIMIZATION IN LOAD FREQUENCY CONTROL  
(LFC).

**Term:** Eight years from 18 August 2021

**Date Granted:** 27 October 2021

**Date Certified:**

**Date of Patent:** 18 August 2021

**Status:** GRANTED

**Expiry Date:** 18 August 2029

**Date Ceased:**

**Date Revoked:**